

BSL - GMB/GMT range of Gas Mixer

Available in both Pre-Set and Adjustable!



About the GMB/GMT range

GMB & GMT Pre-set and adjustable

For Hazardous and non-Hazardous

Flows up to 50 nm³/hr

Supply pressures up to 15 barg

Suitable for applications such as industrial, welding and cutting, food and beverage

Constructed from stainless steel housing, copper tubing and brass compression fittings

Weight: 15 kg

Dimensions: (H x W x D) 166 x 370 x 205 mm

Connections: G1/4 in and G1/4 out

Inlet Pressure: 15 barg max

Mix Accuracy: better than BSEN ISO 14175:2008

Temperature range: -25°C to +50°C, -13°F to +122°F

Our manufacturing procedure conforms to ISO 9001:2008



BSL - GMB/GMT range of Gas Mixer

Available in both Pre-Set and Adjustable!

Design Features



- Good quality materials and cleaning
- Suitable for all common Industrial gases
- Accuracy is to BS EN ISO 14175:2008
- Manufactured to ISO 9001-2008
- Mechanical design so no electrics needed
- Fail safe safety interlock to protect your process
- Gas pressure balancing for constant flow

Design Benefits



- Reliable and robust
- Accurate Gas Mixing
- Resilient to temperature fluctuations
- Guaranteed mixed gas quality
- No electrics needed for the panel to work
- If you lose a supply gas, none of the gases will go through
- Resilient to pressure fluctuations
- No buffer tanks needed
- Simple to install, easy to operate, no bother to look after and inexpensive to buy

BSL - GMB/GMT range of Gas Mixer

Available in both Pre-Set and Adjustable!

Gas Blenders

Blue Aluminium Blender
2 Gas Non-Hazardous

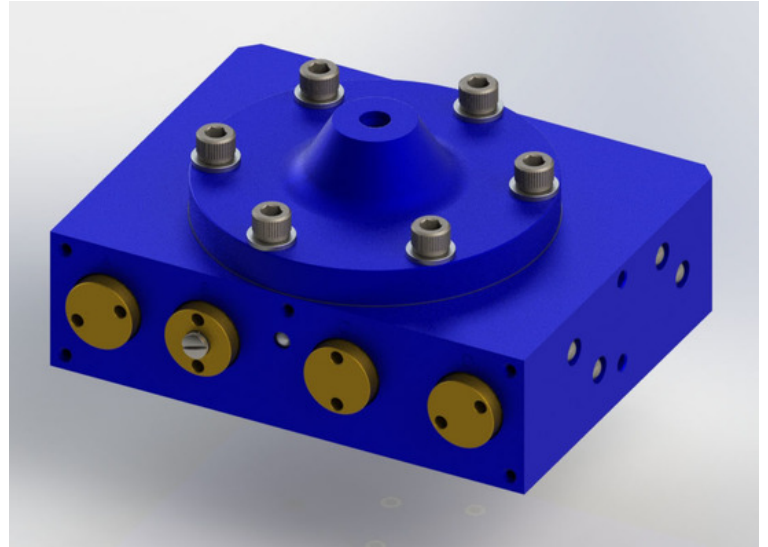

Brass Blender
2 Gas Hazardous
(O₂ & H₂)

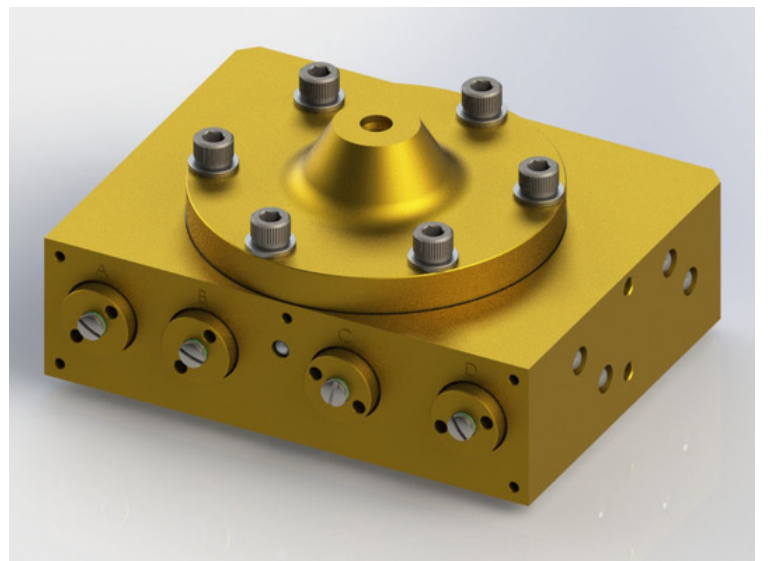

Brass Blender
3 Gas Non-Hazardous &
Hazardous
(CO₂ / Ar / O₂)
(CO₂ / N₂ / O₂)

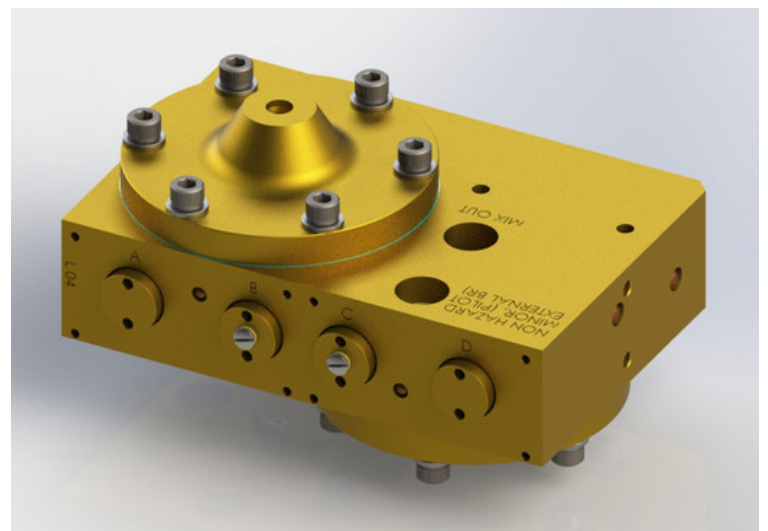

BSL - GMB/GMT range of Gas Mixer

Available in both Pre-Set and Adjustable!

0.01 micron inlet Gas Filters

Our filters will give you extra safe process security. So be secure in the knowledge that your products are as clean as can be!

We have a number of Gas Filters available for the usual industrial gases. Many of which we hold on stock making them available quickly to you.



Leak Detectors

We have a simple in-line leak detector for the purpose of highlighting a leak and giving an idea of the size of it. These are used mainly for our small/ medium sized consumers.

We also produce custom built Smart Gas Management Systems to allow the largest consumers to quantify, locate and fix leaks in their systems.



Gas Analysers

Our Gas Analysers are self-contained units for monitoring gas systems for these gases: CO₂, Argon and Nitrogen. Gas composition is monitored continuously and updated to an LCD screen on the front of the device. High and low alarms, calibration and other parameters may be set via the user interface. Others we have are just a simple display and alarm only system. The View-Mix range is designed to give you an output signal which can be logged on a computer. All systems are available for a range of mixes.



Typical GMB/GMT Installation / P&ID

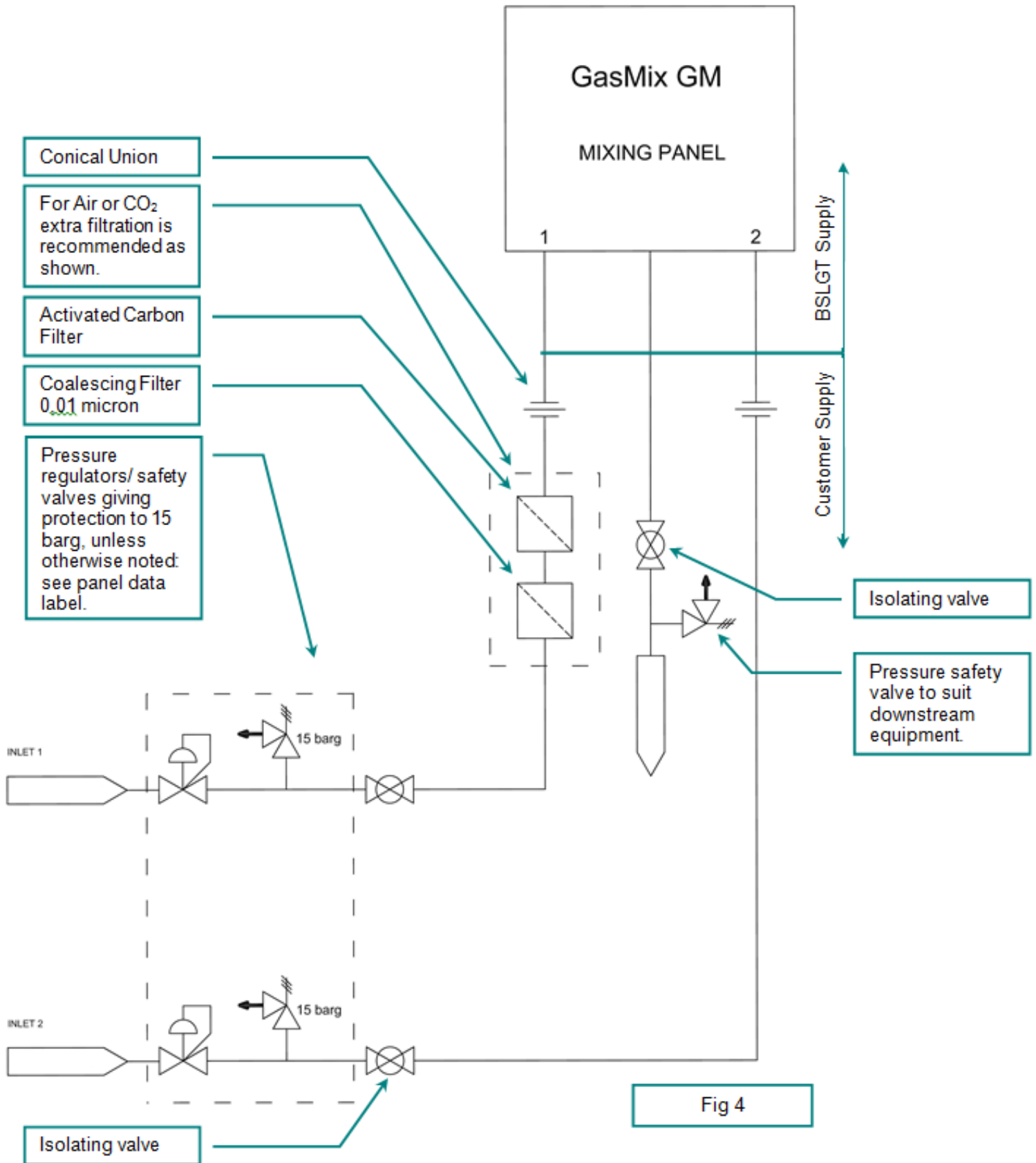

Typical GMB/GMT Installation Drawing / Rendering

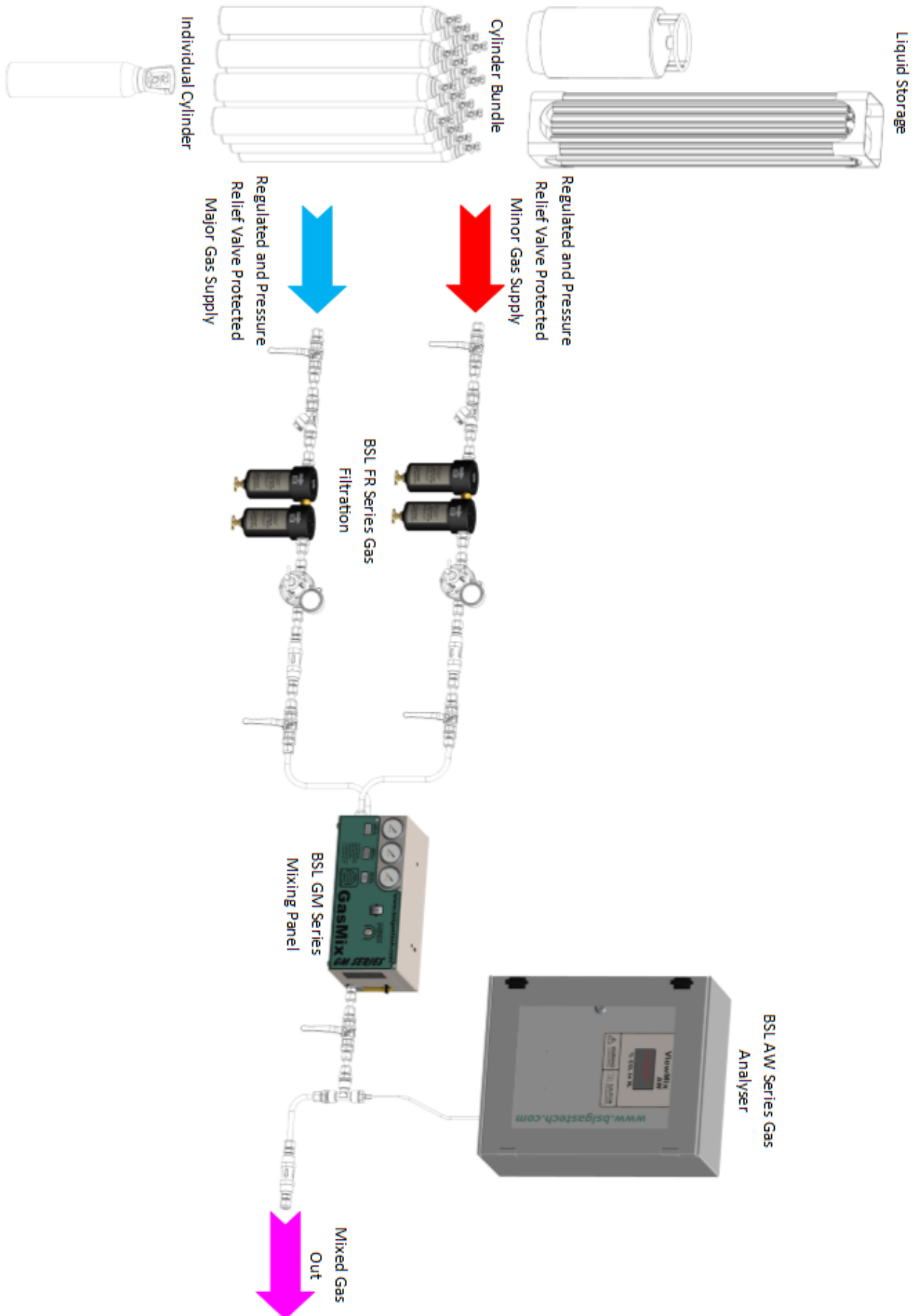

All the FREE benefits of ordering with us!

So what's included?

Full Test Certificate

All of our panels are fully tested and backed up with all relevant test data. A certificate is provided to you giving you peace of mind. This also helps with quality assurance policies.

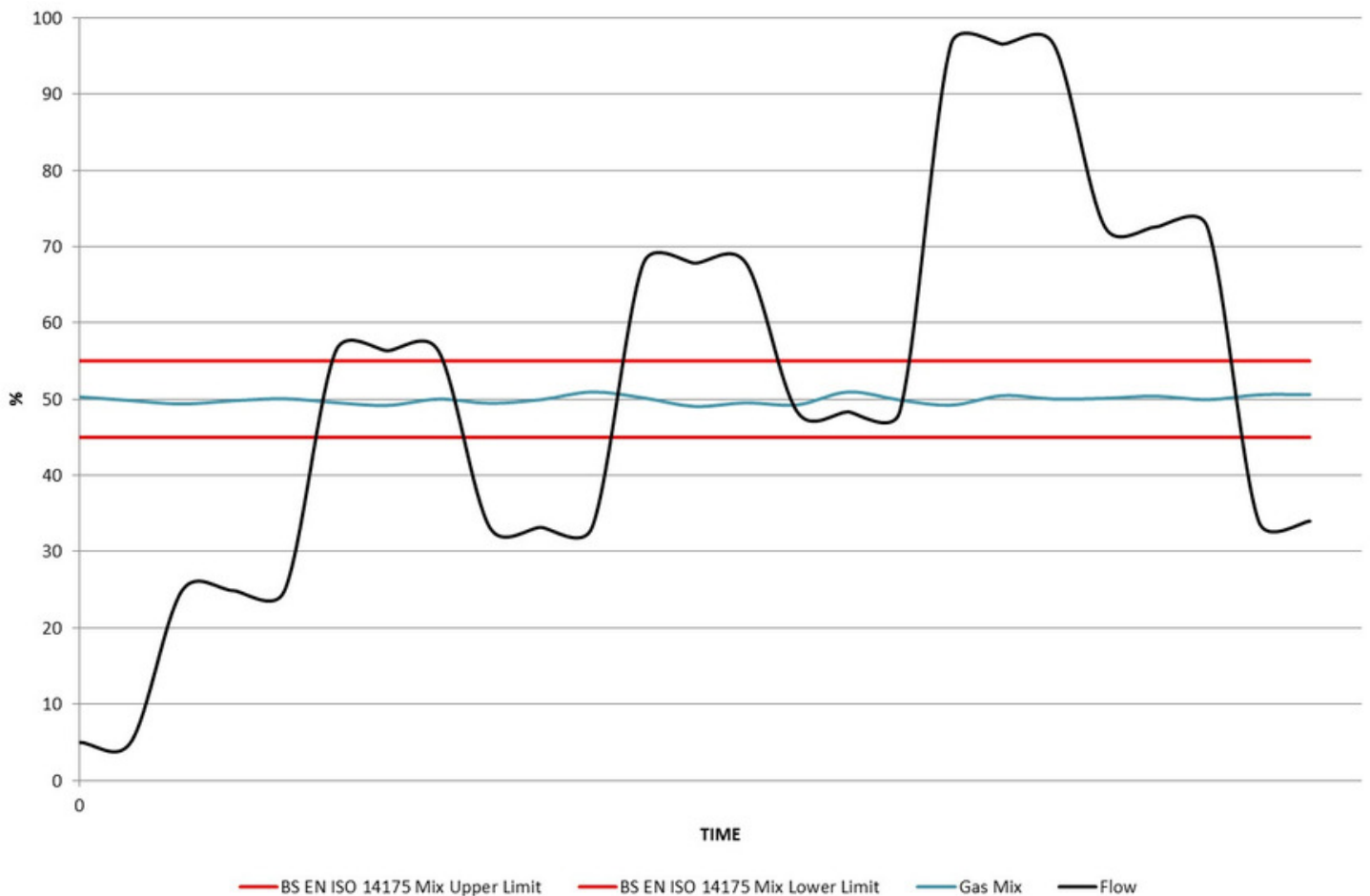

What's included?

Our 3 Year Warranty

Our warranty reflects the confidence we have gained in our equipment over the past 27 years. To the original purchaser we offer a 3 year manufacturers warranty on our Gas Mixing Valves, from the moment they leave us here in Kent UK. We warrant that each Gas Mixing Valve will be free from defects in material and workmanship for at least 3 years of operation, subject to the valve being installed and used properly which is outlined in the instruction manual provided with the panels. If you have more questions on this you can contact us through email: Solutions@bslgastech.com or call us on: +44(0)1634 661100.

Manuals are included for the specific panels with easy to use install instructions. If there is anything you need that is not covered in the manuals, please contact us. We will be happy to help you!

All equipment is well packed and put on a pallet for easy transportation. We can arrange delivery for you or you can have the equipment collected by your own courier. We will of course assist you or your courier with all relevant documentation needed.

We know how important you are and endeavour to help with any queries or advice.



BSL Gas Technologies Ltd

101 Laker Road
Rochester Airport Industrial Estate
Kent ME1 3QX UK

Tel: +44(0)1634 661100
Solutions@bslgastech.com
www.bslgastech.com

